

双锁紧不锈钢防水接头

- 产品材料:** 默认304, 可选316及316L, 密封件为EPDM橡胶
- 防护等级:** IP68
- 工作温度:** -40° ~ 105°, 短时120°
- 阻燃等级:** UL94V-2, 可定制V0级阻燃
- 产品性能:** 具有双层锁紧特性, 可有效保护电缆, 抗拉力强

•订购说明:

- 1) 默认发货不附螺母, 如需另外订购;
- 2) 默认为304材质, 如需316, 请将型号后缀 "-SS" 改成 "S316"
- 3) 产品价格为 (人民币: 元/套, 美元: USD/set) ;

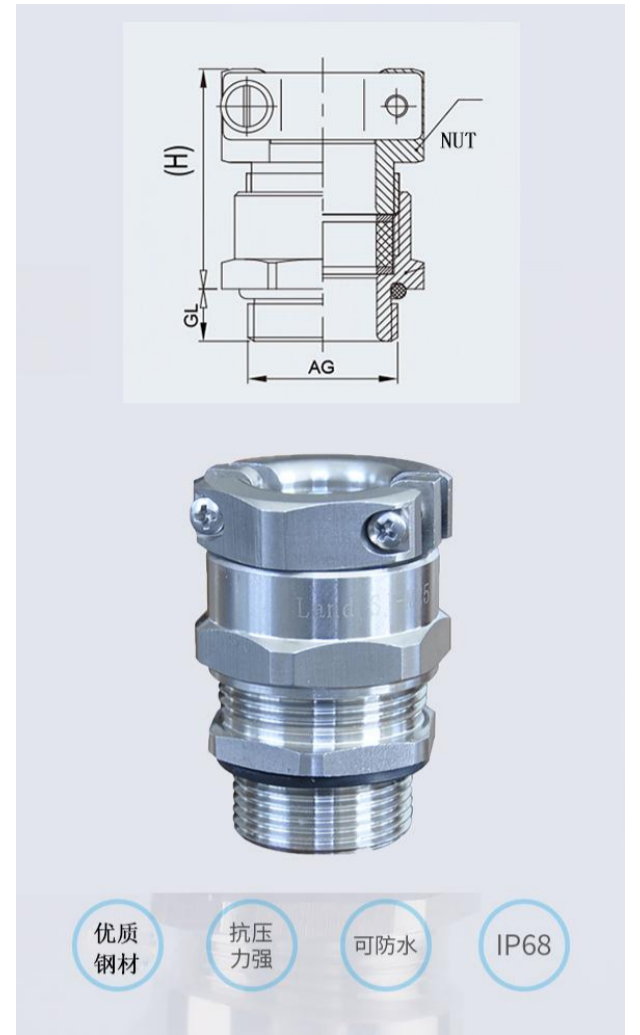

Double locking stainless steel waterproof gland

- Product material:** default 304, optional 316 and 316L, seal is EPDM rubber
- Protection grade:** IP68
- Operating temperature:** - 40 °~105 °, short-term 120 °
- Flame retardant grade:** UL94V-2, customized V0 flame retardant
- Product performance:** It has double-layer locking characteristics, can effectively protect the cable, and has strong tensile resistance

•Ordering instructions:

- 1) The default delivery does not include nuts, if you need to order separately;
- 2) The default is 304 material. If 316 is required, please change the model suffix "- SS" to "S316"
- 3) The product price is (RMB: yuan/set, USD: USD/set);

产品应用场合/Application occasion



公制螺纹/Metric thread

蓝江产品型号	螺纹规格	电缆范围	螺纹长度	扳手尺寸
Product model	Thread size	Cable range	Thread length	Wrench Size
PN.	Metric	φ mm	GL mm	nut/cap mm
SJ-MG12-08-SS	M12×1.5	4~8	9	15/17
SJ-MG16-08-SS	M16×1.5	4~8	9.5	20/17
SJ-MG16-10-SS	M16×1.5	6~10	9.5	20/21
SJ-MG18-10-SS	M18×1.5	6~10	9.5	21/21
SJ-MG20-14-SS	M20×1.5	8~14	12	24/26
SJ-MG20-12-SS	M20×1.5	8~12	12	24/26
SJ-MG22-14-SS	M22×1.5	8~14	12	26/26
SJ-MG24-14-SS	M24×1.5	8~14	10.5	28/26
SJ-MG25-18-SS	M25×1.5	13~18	12	30/32
SJ-MG25-16-SS	M25×1.5	12~16	12	30/32
SJ-MG27-18-SS	M27×1.5/2.0	13~18	12	30/32
SJ-MG30-18-SS	M30×1.5/2.0	13~18	12.5	34/32
SJ-MG32-25-SS	M32×1.5	18~25	12.5	38/40
SJ-MG32-22-SS	M32×1.5	17~22	12.5	38/40
SJ-MG33-22-SS	M33×2.0	17~22	14.5	38/40
SJ-MG36-25-SS	M36×1.5/2.0	18~25	13	42/40
SJ-MG40-31-SS	M40×1.5/2.0	25~31	14	48/50
SJ-MG40-25-SS	M40×1.5/2.0	18~25	14	48/50
SJ-MG40S-25-SS	M40×1.5	18~25	14	48/40
SJ-MG40S-22-SS	M40×1.5	17~22	14	48/40
SJ-MG42-31-SS	M42×2.0	25~31	15	48/50
SJ-MG42-25-SS	M42×2.0	18~25	15	48/50
SJ-MG48-31-SS	M48×2.0	25~31	15	58/50
SJ-MG48-25-SS	M48×2.0	18~25	15	58/50
SJ-MG50-41-SS	M50×1.5	33~41	15	58/60
SJ-MG50-33-SS	M50×1.5	25~33	15	58/60
SJ-MG50S-31-SS	M50×1.5	25~31	15	54/50
SJ-MG50S-25-SS	M50×1.5	18~25	15	54/50
SJ-MG60-44-SS	M60×2.0	36~44	15	71/65
SJ-MG63-54-SS	M63×1.5	46~54	15	71/76
SJ-MG63S-44-SS	M63×1.5	36~44	15	71/65

PG螺纹/PG thread

蓝江产品型号	螺纹规格	电缆范围	螺纹长度	扳手尺寸
Product model	Thread size	Cable range	Thread length	Wrench Size
PN.	PG	mm	mm	nut/cap mm
PG7-08-SS	PG7	4~8	9	15/17
PG9-08-SS	PG9	4~8	9	17/17
PG11-10-SS	PG11	6~10	9.5	21/21
SJ-PG13.5-14-SS	PG13.5	8~14	10.5	24/26
SJ-PG13.5-12-SS	PG13.5	7~12	10.5	24/26
SJ-PG16-14-SS	PG16	8~14	12	26/26
SJ-PG16-12-SS	PG16	8~12	12	26/26
SJ-PG19-14-SS	PG19	8~14	10.5	28/26
SJ-PG21-18-SS	PG21	13~18	12	32/32
SJ-PG21-16-SS	PG21	12~16	12	32/32
SJ-PG21-14-SS	PG21	8~14	12	32/32
SJ-PG21-10-SS	PG21	6~10	12	32/32
SJ-PG25-18-SS	PG25	13~18	12.5	34/32
SJ-PG25-16-SS	PG25	12~16	12.5	34/32
SJ-PG29-25-SS	PG29	18~25	12.5	40/40
SJ-PG29-22-SS	PG29	17~22	12.5	40/40
SJ-PG36-31-SS	PG36	25~31	15	58/50
SJ-PG36-25-SS	PG36	18~25	15	58/50
SJ-PG42-41-SS	PG42	33~41	15	60/60
SJ-PG42-33-SS	PG42	25~33	15	60/60
SJ-PG48-44-SS	PG48	36~44	15	71/65

G和NPT螺纹/G and NPT thread

蓝江产品型号	螺纹规格	电缆范围	螺纹长度	扳手尺寸
Product model	Thread size	Cable range	Thread length	Wrench Size
PN.	G(PF)	mm	mm	nut/cap mm
SJ-G1/2-14-SS	G1/2	8 ~ 14	12	24/26
SJ-G1/2-12-SS	G1/2	7 ~ 12	12	24/26
SJ-G3/4-18-SS	G3/4	13 ~ 18	12	30/31
SJ-G3/4-16-SS	G3/4	12 ~ 16	12	30/31
SJ-G1-25-SS	G1	18 ~ 25	15	38/40
SJ-G1-22-SS	G1	17 ~ 22	15	38/40
SJ-G1-1/4-31-SS	G1-1/4	25 ~ 31	15	48/50
SJ-G1-1/4-25-SS	G1-1/4	18 ~ 25	15	48/50
SJ-G1-1/2-41-SS	G1-1/2	33 ~ 41	15	55/60
SJ-G1-1/2-33-SS	G1-1/2	25 ~ 33	15	55/60
SJ-G1-1/2-31-SS	G1-1/2	25 ~ 31	15	55/50
SJ-G1-1/2-25-SS	G1-1/2	18 ~ 25	15	55/50
SJ-G2-44-SS	G2	36 ~ 44	15	71/65
SJ-NPT1/2-14-SS	NPT1/2	8 ~ 14	13	24/26
SJ-NPT1/2-12-SS	NPT1/2	7 ~ 12	11	24/26
SJ-NPT3/4-18-SS	NPT3/4	13 ~ 18	13	30/31
SJ-NPT3/4-16-SS	NPT3/4	12 ~ 16	13	30/31
SJ-NPT1-25-SS	NPT1	18 ~ 25	15	38/40
SJ-NPT1-22-SS	NPT1	17 ~ 22	15	38/40
SJ-NPT1-1/4-31-SS	NPT1-1/4	25 ~ 31	15	48/50
SJ-NPT1-1/4-25-SS	NPT1-1/4	18 ~ 25	15	48/50
SJ-NPT1-1/2-41-SS	NPT1-1/2	33 ~ 41	15	55/60
SJ-NPT1-1/2-33-SS	NPT1-1/2	25 ~ 33	15	55/60
SJ-NPT1-1/2-31-SS	NPT1-1/2	25 ~ 31	15	55/50
SJ-NPT1-1/2-25-SS	NPT1-1/2	18 ~ 25	15	55/50
SJ-NPT2-44-SS	NPT2	36 ~ 44	15	71/65